

Replacement parts lists

12. Replacement parts lists

1. Baseframe	160
2. Work surface	161
3. Motor with lifting cylinder and tool shelf	161
4. Centre stop	162
5. Press-in frame	162
6. Hold-down clamp	163
7. Stroke limiter	164
8. Drum stop	164
9. Interchangeable drilling unit, 90°, 9 spindles	165
10. Interchangeable drilling unit, 9 spindles	167
11. Interchangeable drilling unit, 6 spindles	167
12. Interchangeable drilling unit, 3 spindles, Selekt (22/9)	168
13. Pneumatics diagram	169
14. Circuit diagram	170

en

1. Base frame

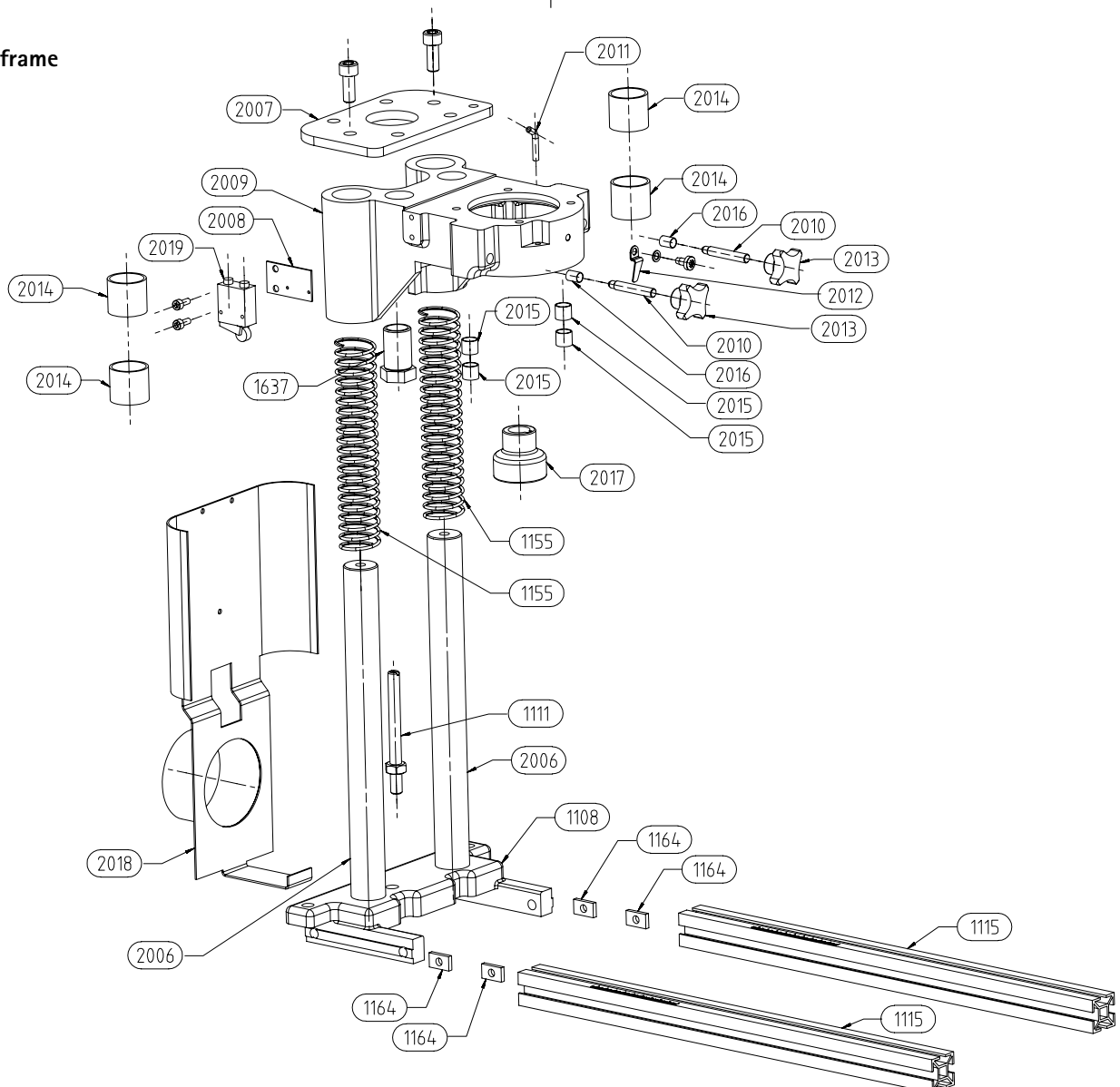

2. Work surface

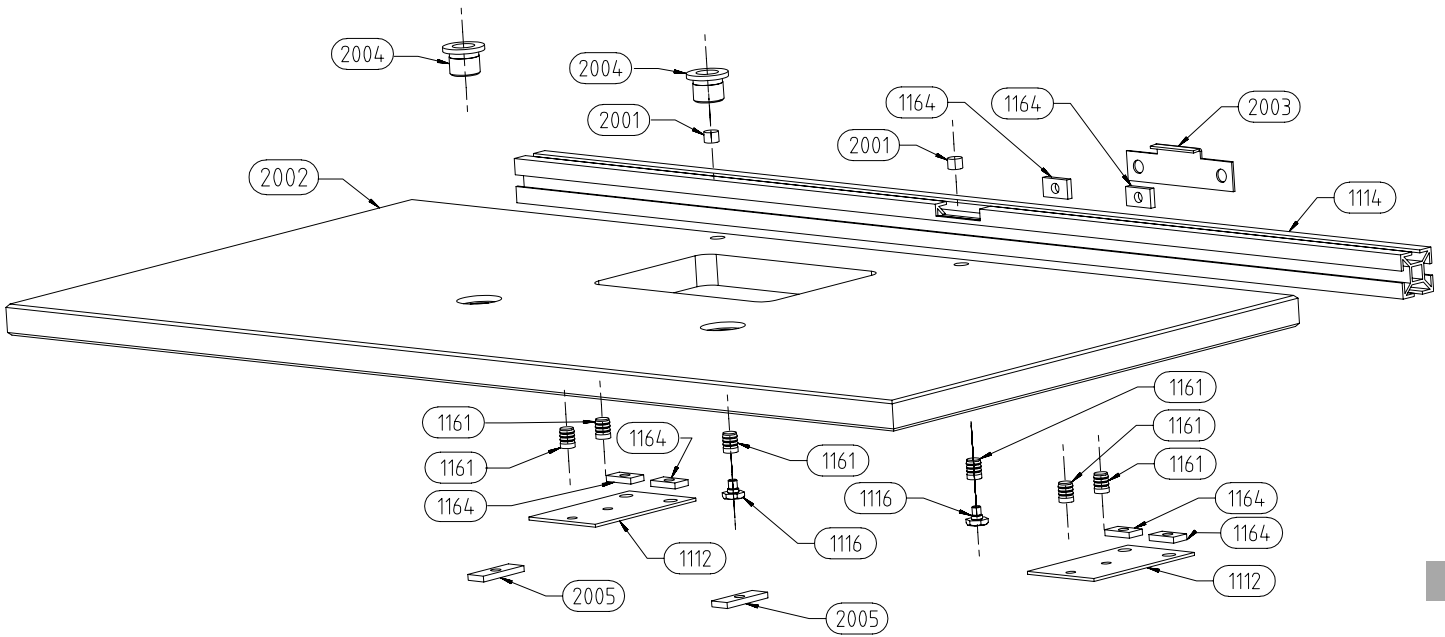

en

3. Motor with lifting cylinder and tool shelf

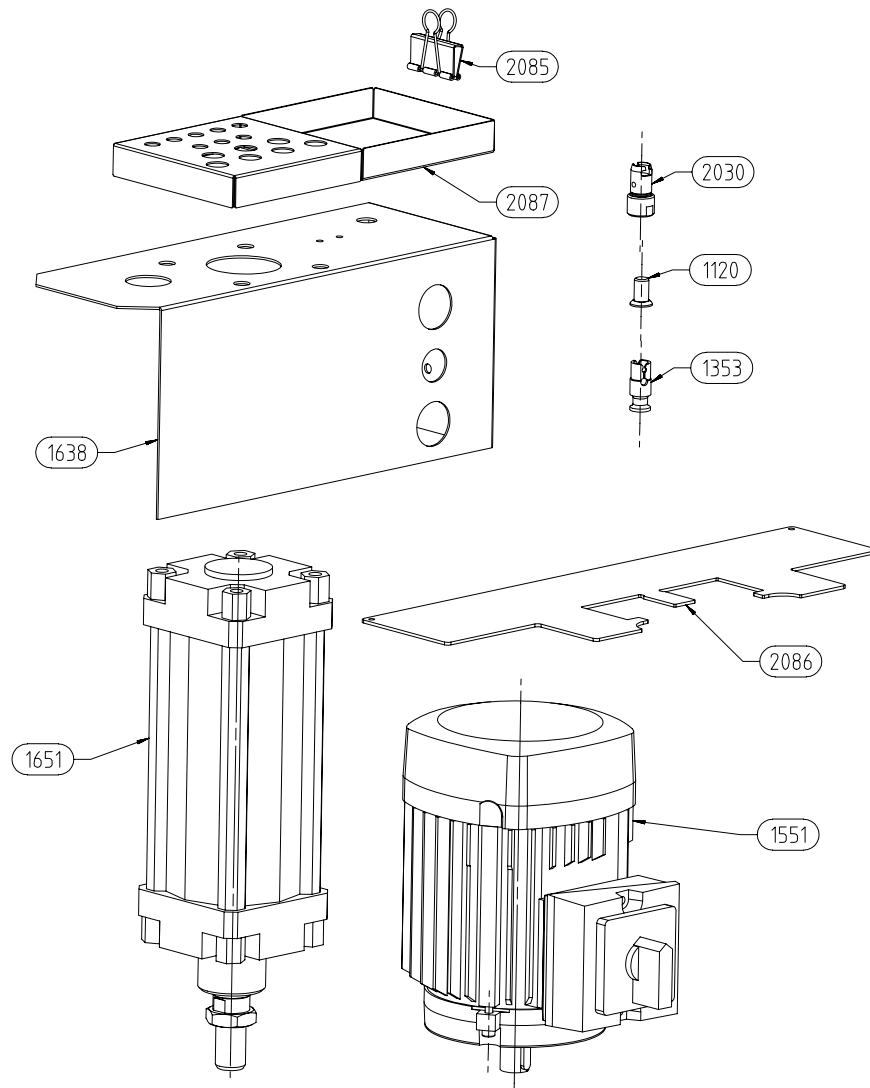

Replacement parts lists

4. Centre stop

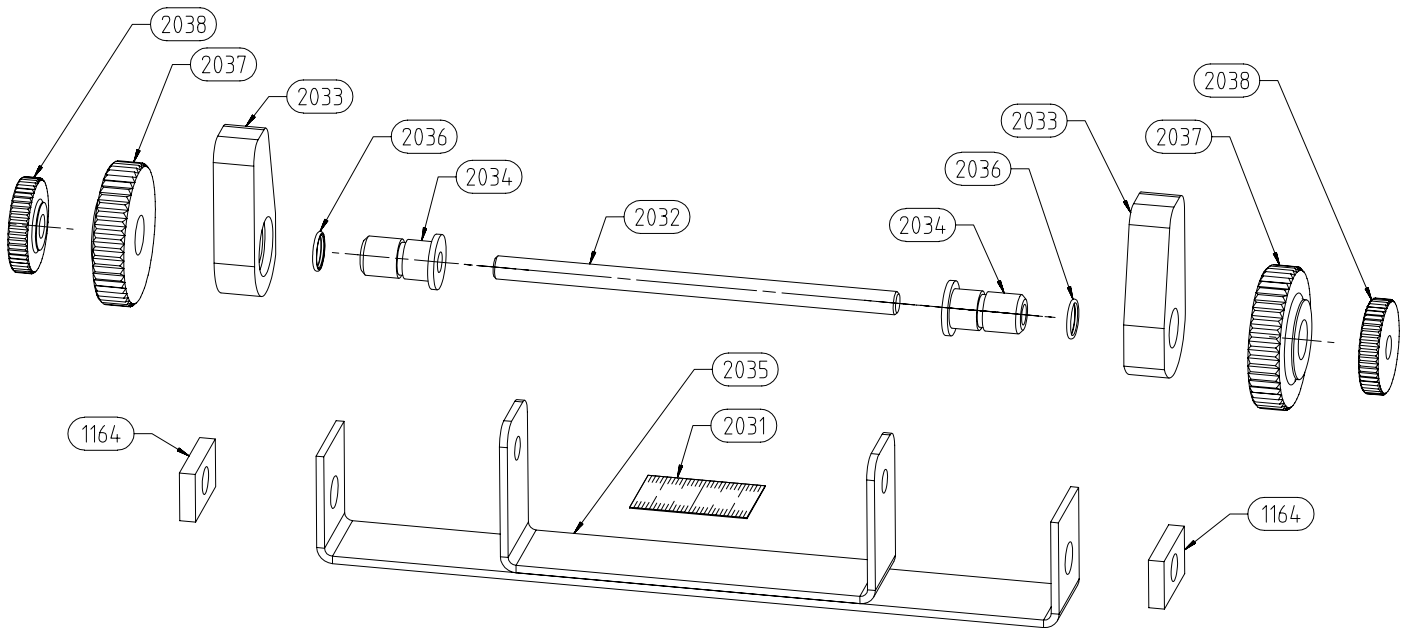

5. Press-in frame

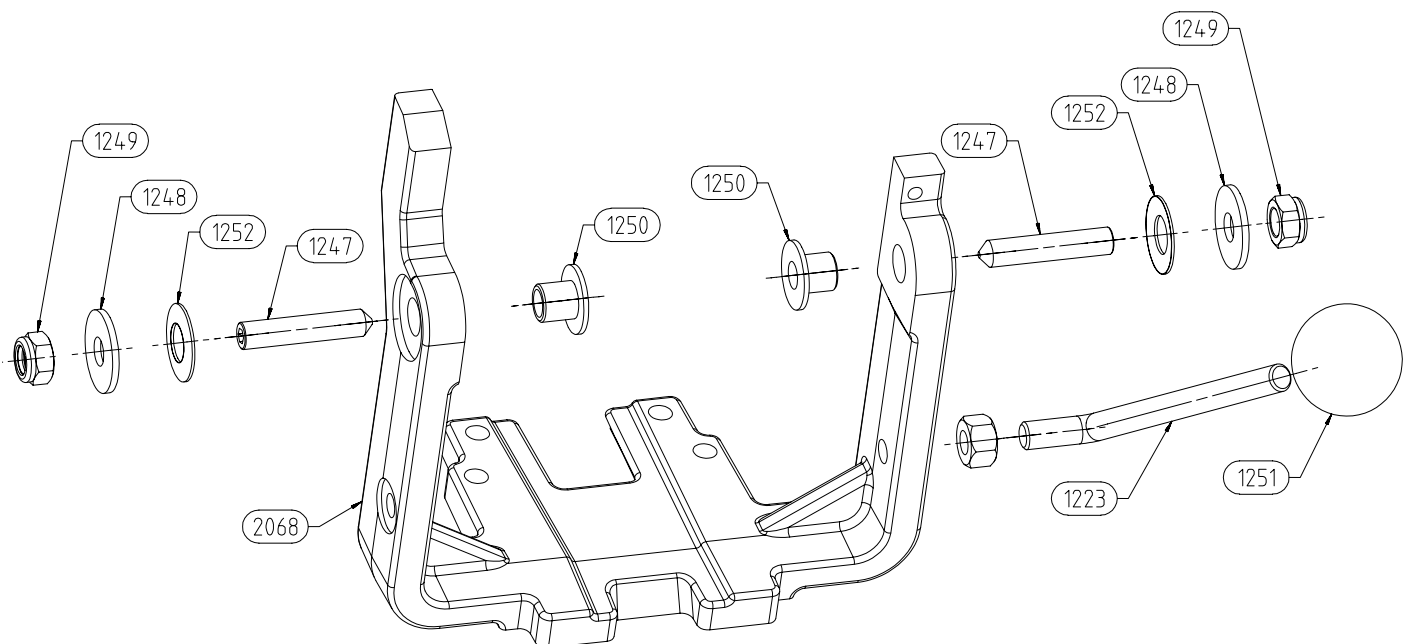

6. Hold-down clamp

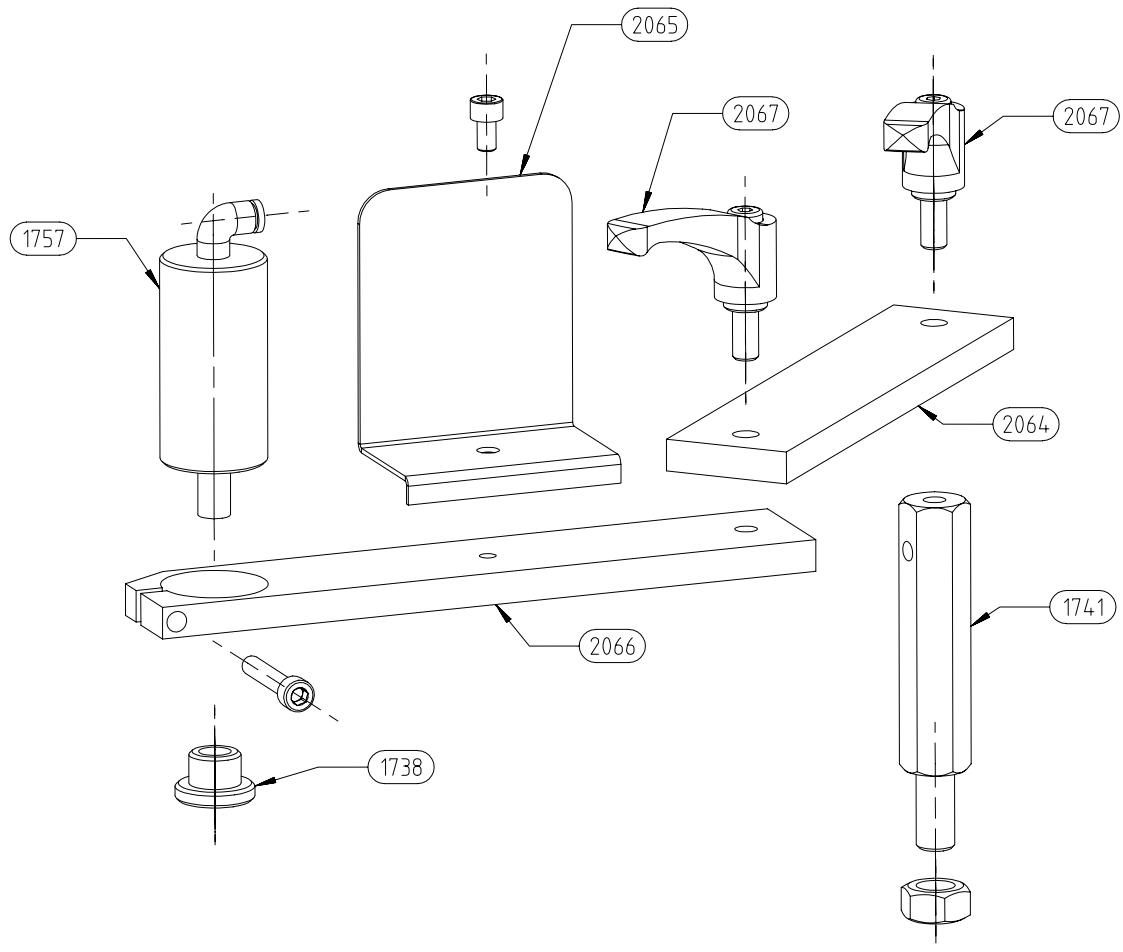

en

Replacement parts lists

7. Stroke limiter

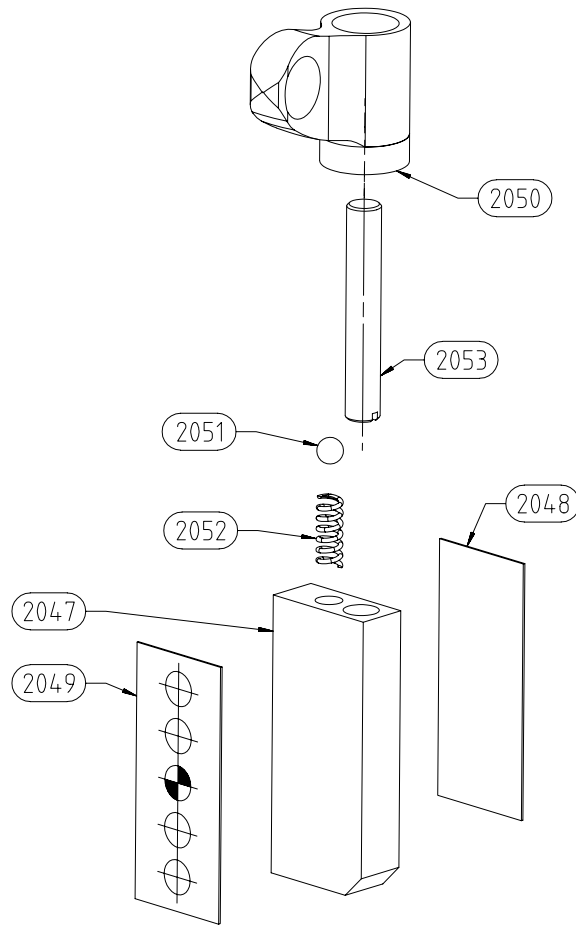

8. Drum stop

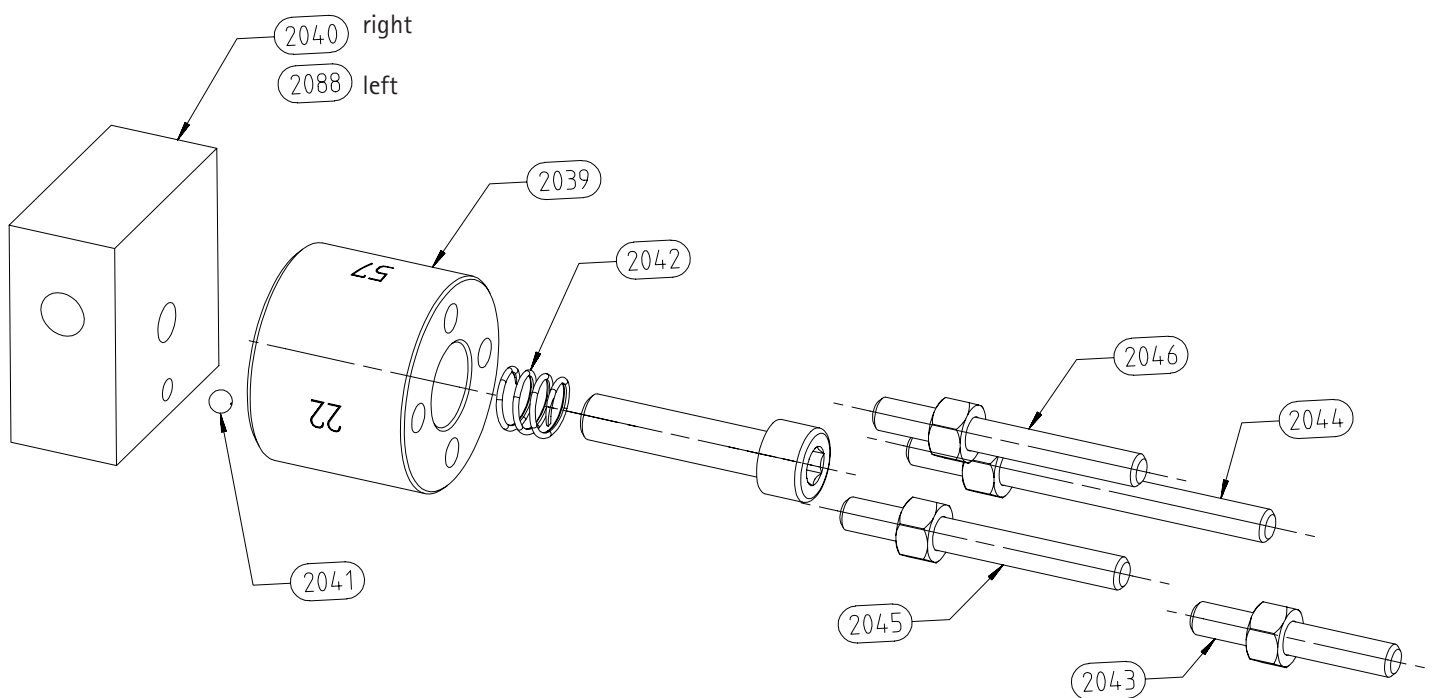

9. Interchangeable drilling unit, 90°, 9 spindles

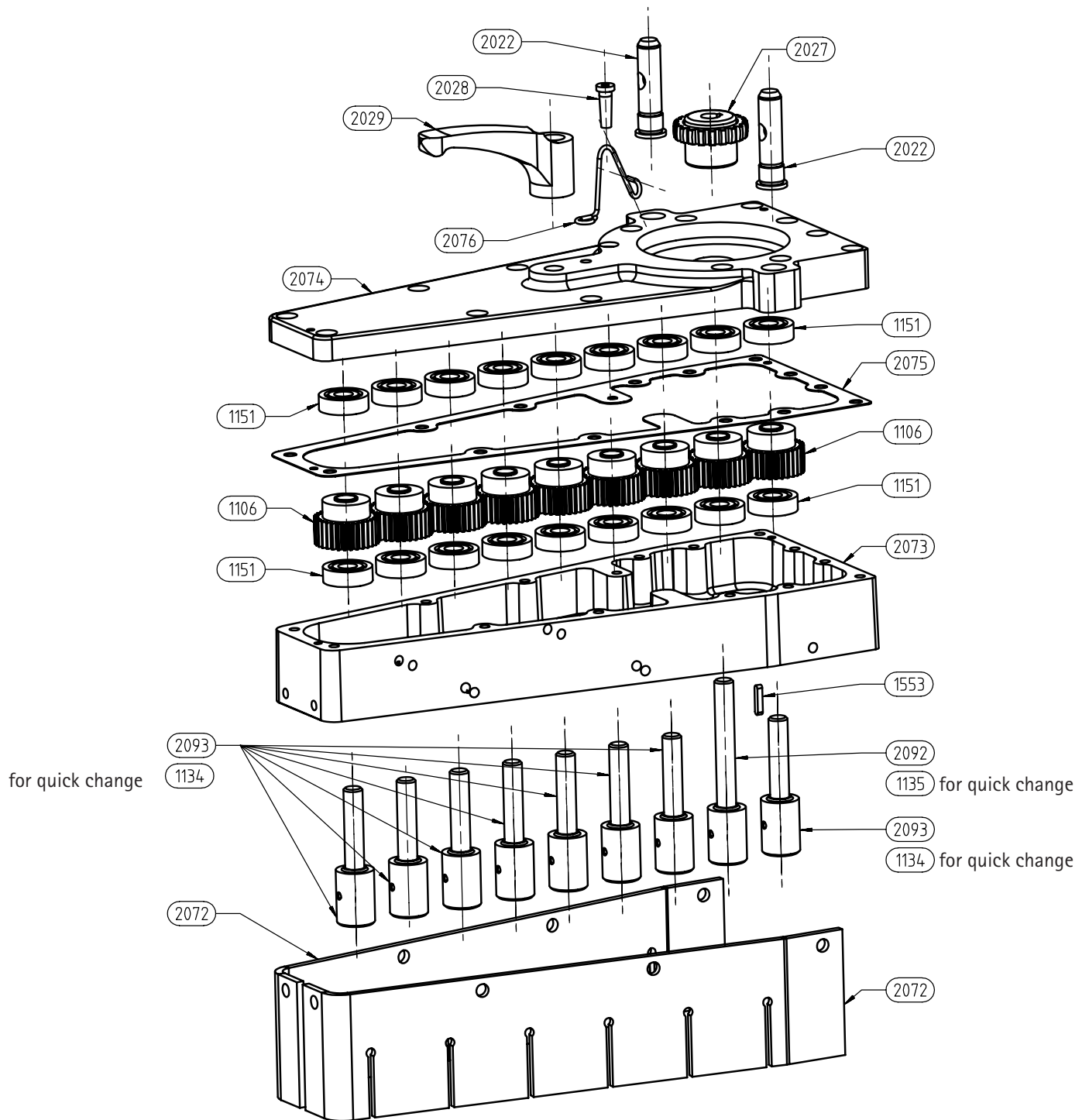

en

Replacement parts lists

10. Interchangeable drilling unit, 9 spindles

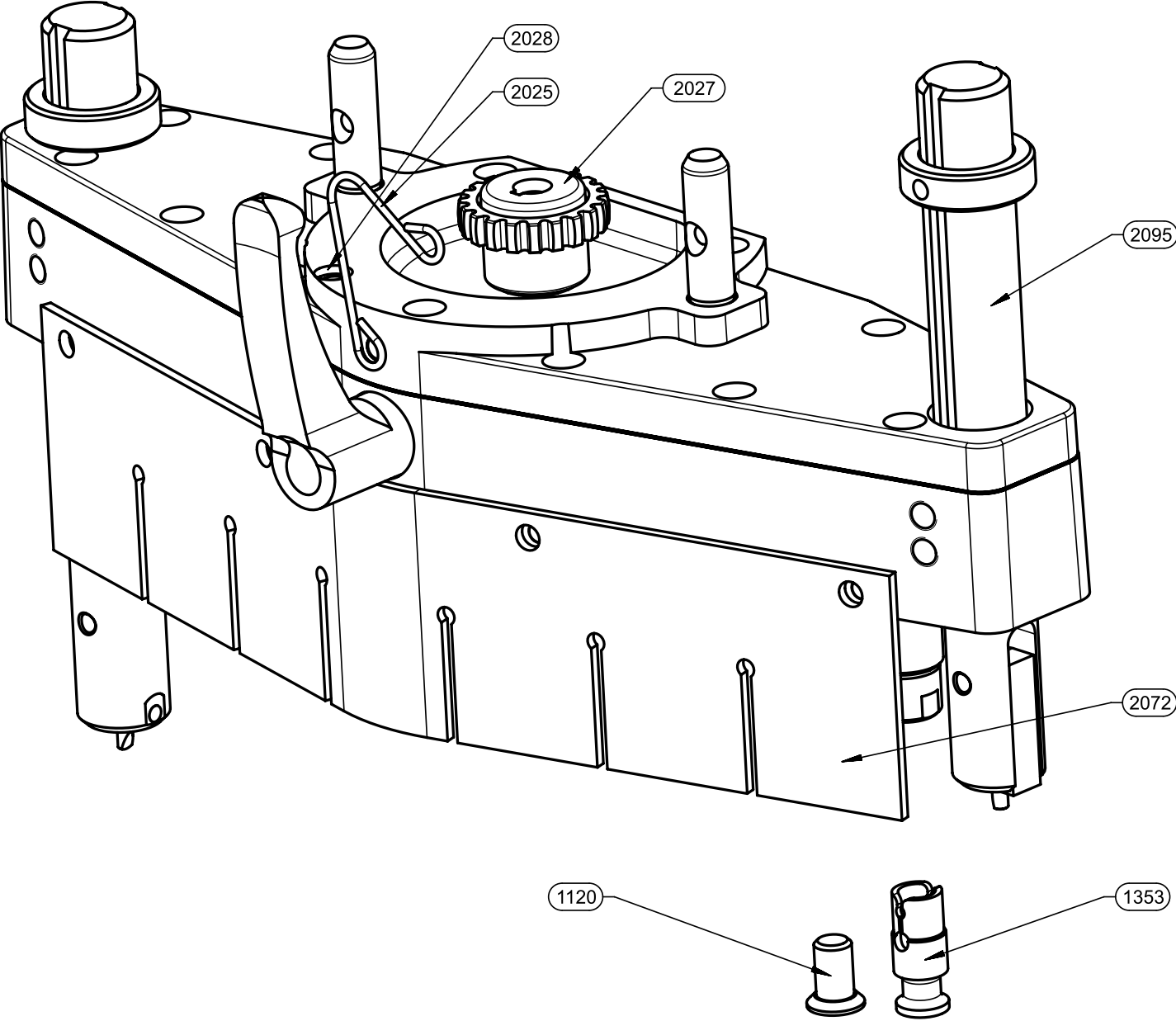

en

11. Interchangeable drilling unit, 6 spindles

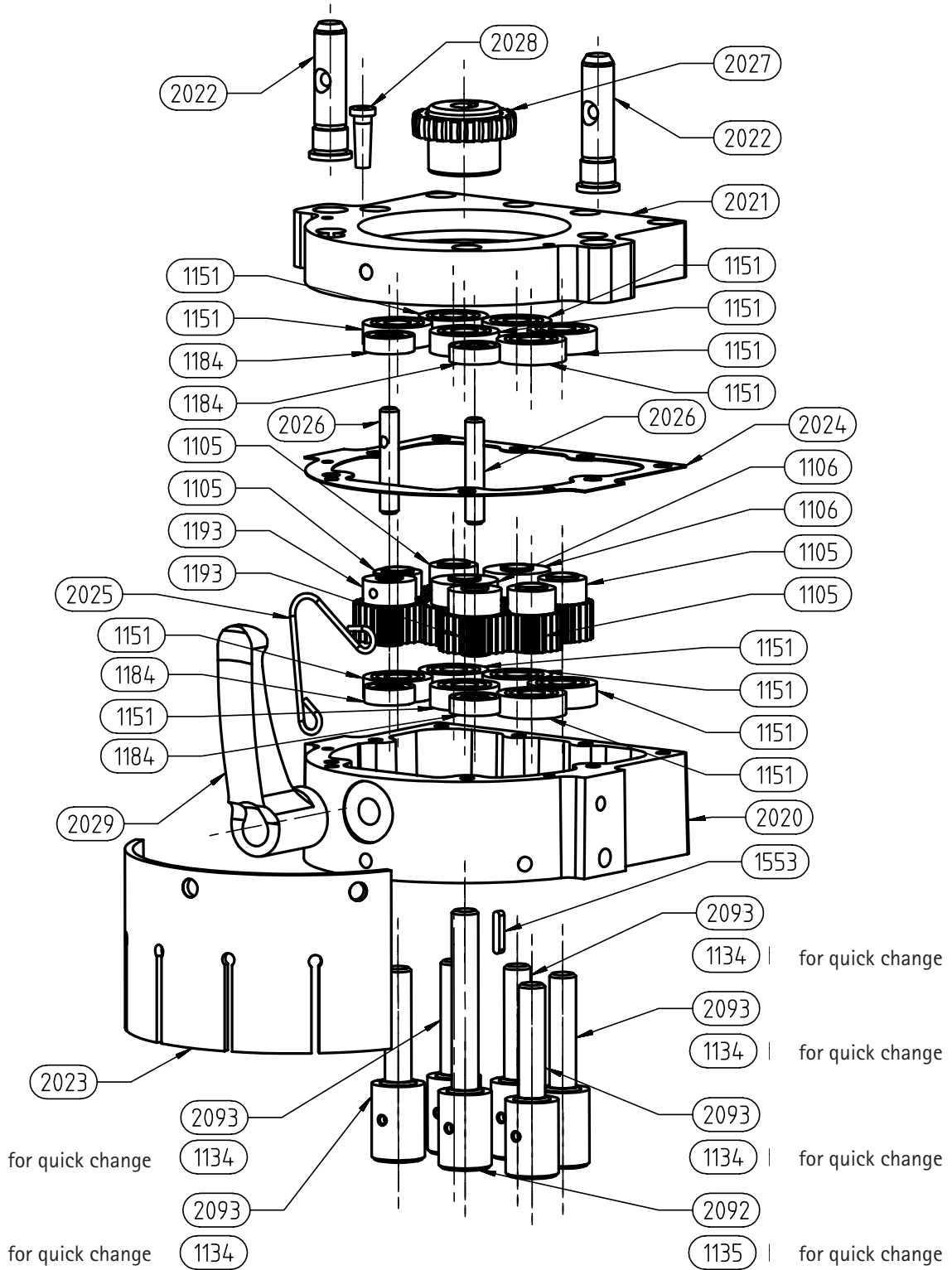

Replacement parts lists

12. Interchangeable drilling unit, 3 spindles, Selektta (22/9)

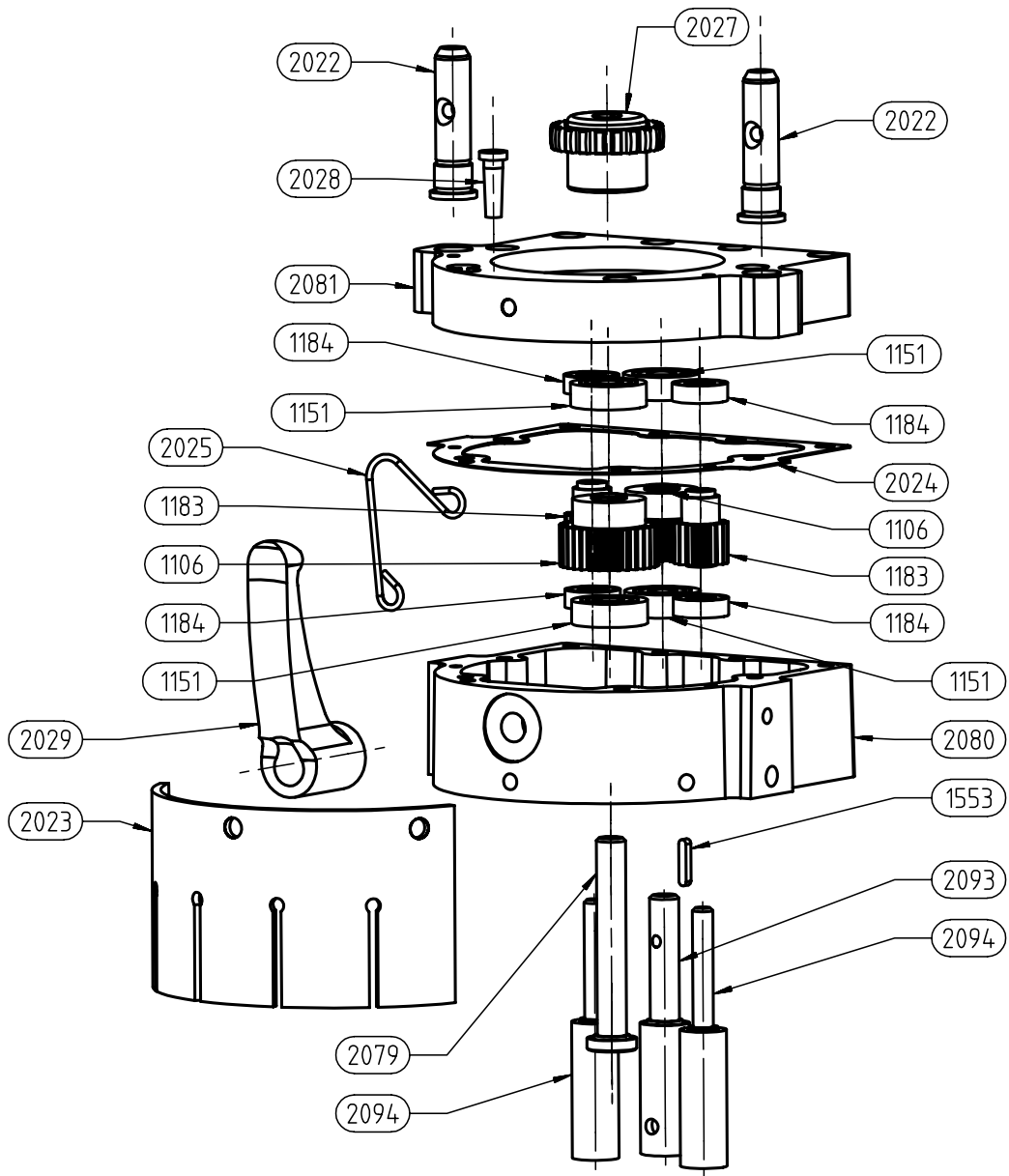

en

13. Replacement part numbers

Replacement part no.	Designation
1103	Auxiliary spindle with chuck
1104	Main spindle with chuck
1105	Pinion, teeth = 21
1106	Pinion, teeth = 32
1108	Base plate
1111	Drill depth stop M 12 x 1
1112	Guide plate
1114	Fence 800 mm
1115	Base profile 465 mm
1116	Guide screw M 6 x 12
1120	Cap for chuck
1134	Auxiliary spindle quick-release chuck
1135	Main spindle quick-release chuck
1151	Deep groove ball bearing 6000 - RS
1155	Compression spring PM
1160a	Angled screw connection 1/8" (longer shank)
1161	Knock-in socket \varnothing 10 x 12
1164	Square nut DIN 562 - M 8
1183	Pinion, teeth = 17
1184	Customised deep groove ball bearing 607 - 2RS
1190	Customised auxiliary spindle with chuck
1193	Pinion, teeth = 25
1197	Pinion, teeth = 23
1223	Handle rod for swivel unit
1247	Threaded stud DIN 553 - M8 x 40
1248	Large-diameter washer DIN 9021- A 8.4
1249	Self-locking hexagon nut DIN 982 - M 8
1250	Bush
1251	Spherical knob
1252	Spring washer DIN 2093 B 22.5 size 1
1264	Angled screw connection M 5 swivelling \varnothing 4 mm
1353	Cap for quick-release chuck
1551	Motor with switch = following information must be provided: 1. Machine type 2. Serial number 3. Voltage, hertz, phases, power output in kW
1553	Feather key for coupling DIN 6885 - A 3 x 3 x 16
1637	Coupling for piston rod, including nut
1638	Control console
1651	Pneumatic cylinder DW 80 / 125
1656	5/2-way pushbutton valve 1/8"

Replacement part no.	Designation
1659	Angled screw connection 1/4"
1661	Push-fit straight screwed connection 1/8" \varnothing 6 mm
1662	Sound absorber 1/8"
1663	Discharge air, throttle type nonreturn valve
1664	Reduction nipple 1/41 x 3/8 A
1665	Servicing unit assy 1/4"
1671	Plug connector NW 7.2
1680	Electro-pneumatic switch with cable = following information must be provided: 1. Serial number 2. Voltage, hertz, phases, power output in kW
1684	Plug \varnothing 6 mm
1686	Plug \varnothing 4 mm
1688	Rapid bleeder valve G 1/8"
1689	Reduction nipple 1/8" l x 3/8" A
1690	Angled screw connection, tapered, 2 x 1/8"
1738	Pressure plate for hold-down clamp
1741	Bolt for hold-down clamp
1757	Pneumatic round cylinder, \varnothing 33 mm
1760	Plug connector, twin connection \varnothing 6 mm
1763	Sound absorber M 5
1765	Plug connector, twin connection \varnothing 4 mm (3 x \varnothing 4 mm)
1766	Push-fit cross connection \varnothing 4 mm
1779	3/2-way valve M5, spring-returning
1783	Plug in reducing connector
1953	5/2-way valve 1/8"
1955	3/2-way foot valve 1/8"
1956	Double nipple M5-M5
1964	Push-fit angled screw connection R 1/8 \varnothing 4 mm MR 14.04.18
2001	Skiffy machine foot, grey polyethylene
2002	Work surface, BlueMax Mini Modular
2003	Centre stop 39
2004	Insert for work surface
2005	Grooved nut M long
2006	Guide column, BlueMax Mini Modular
2007	Bridge, BlueMax Mini Modular
2008	Valve plate for PC104 valve series
2009	Motor mount, BlueMax Mini Modular
2010	Tensioning spindle, BlueMax Mini Modular
2011	Pipe for discharge air, BlueMax Mini Modular
2012	Sliding plate, BlueMax Mini Modular

Replacement part no.	Designation
2013	Star handle, grey cast iron, M 8 blind hole
2014	Plain bearing IGUS J 30 x 34 - 30
2015	DU bushing, cylindrical
2016	Wire thread insert M 8
2017	Bowex Junior size 19 d14 plug-in socket 2b
2018	Cover assy
2019	Pushbutton roller valve NO d4 linear
2020	Drilling-unit block, 6-sp., MT BlueMax Mini Modular
2021	Drilling-unit cover, 6-sp., MT BlueMax Mini Modular
2022	Clamp pin
2023	Drill-bit guard 6-sp
2024	Seal, 6-sp. BlueMax Mini Modular
2025	Wire spring, BlueMax Mini Modular
2026	Dummy spindle
2027	Bowex Junior size 19 d10 hub 1b
2028	Cable sleeve (for blow nozzle, BlueMax Mini Modular)
2029	Clamping lever, rigid, M10 grip length 78
2030	Drill holder with pressure plate and grub screw
2031	Scale sticker, BlueMax Mini Modular
2032	Threaded rod M 6 103 lg
2033	Lever, reworked
2034	Adjusting sleeve, BlueMax Mini Modular
2035	Double U-holder, BlueMax Mini Modular
2036	O-ring
2037	Knurled nut, shallow
2039	Drum, BlueMax Mini Modular
2040	Drum holder, right
2041	Ball, quality class 3
2042	Compression spring
2043	Stop L1 38 long, BlueMax Mini Modular
2044	Stop L2 68 long, BlueMax Mini Modular
2045	Stop L3 53 long, BlueMax Mini Modular
2046	Stop L4 50 long, BlueMax Mini Modular
2047	Stop pawl, BlueMax Mini Modular
2048	Sticker, hinge
2049	Sticker, hole line
2050	Wing nut, one-sided, M 8 cap red
2051	Ball, quality class 3
2052	Compression spring D1.0 x D6.0 x 16
2053	Shaft screw
2064	Extension plate for hold-down clamp, BlueMax Mini Modular

Replacement part no.	Designation
2065	Collision guard, BlueMax Mini Modular
2066	Clamping plate for pneum. hold-down clamp, BlueMax Mini Modular
2067	Clamping lever, adjustable
2068	Swivel unit
2069	Drilling unit block 9R
2070	Drilling unit cover 9
2071	Seal, 9-sp. BlueMax Mini Modular
2072	Drill-bit guard 9R/9W BlueMax Mini Modular
2073	Drilling unit block, 9-sp. 9W BlueMax Mini Modular
2074	Drilling unit cover, 9-sp. 9W BlueMax Mini Modular
2075	Seal, 9-sp. 9W, BlueMax Mini Modular
2076	Wire spring, 9W, BlueMax Mini Modular
2077	Drilling unit block, 3-sp. Selecta 52/9 BlueMax Mini Modular
2078	Drilling unit cover, 3-sp. Selecta 52/9 BlueMax Mini Modular
2079	Main spindle (special)
2080	Drilling unit block, 3-sp. 45/9.5 BlueMax Mini Modular
2081	Drilling unit cover, 3-sp. 45/9.5 BlueMax Mini Modular
2082	Non-return valve M 5
2083	Discharge air non-return valve, throttle-type, block form d4
2084	Rotary switch valve 22-way d4 N.C.
2085	Foldback clip 2154190 black 41 mm
2086	Set-up template, BlueMax Mini Modular
2087	Tool shelf, BlueMax Mini Modular, powder coated
2088	Drum holder, left
2089	"Caution" sticker, control panel
2090	Drilling unit block 38-9
2091	Drilling unit cover 38-9
2092	Special main spindle
2093	Special auxiliary spindle d10
2094	Special auxiliary spindle d7
2095	Continuation stop
2097	Motor protection circuit breaker 1 - 1,6A
2098	Motor protection circuit breaker 4,6 - 2,5A
2099	Motor protection circuit breaker 4 - 6,3A
2100	Motor protection circuit breaker 2,5 - 4A
2101	Motor protection circuit breaker 6,3 - 10A
2102	Motor protection circuit breaker 10 - 16A
2103	Insulated enclosure